

22-197

UNDERWATER TELEMETER FOR DEPTH AND TEMPERATURE

Marine Biological Laboratory
LIBRARY
400
WOODS HOLE, MASS.



SPECIAL SCIENTIFIC REPORT-FISHERIES No. 181

UNITED STATES DEPARTMENT OF THE INTERIOR
FISH AND WILDLIFE SERVICE

EXPLANATORY NOTE

The series embodies results of investigations, usually of restricted scope, intended to aid or direct management or utilization practices and as guides for administrative or legislative action. It is issued in limited quantities for official use of Federal, State or cooperating agencies and in processed form for economy and to avoid delay in publication.

UNITED STATES DEPARTMENT OF THE INTERIOR, Fred A. Seaton, Secretary
Fish and Wildlife Service, John L. Farley, Director

UNDERWATER TELEMETER FOR
DEPTH AND TEMPERATURE

By

F. H. Stephens, Jr., and F. J. Shea

SPECIAL SCIENTIFIC REPORT - FISHERIES No. 181

Washington, D. C.

June 1956

This report describes the construction of a telemetering depth-measuring instrument to be used with midwater trawling devices in exploratory fishing and gear research. The objective in developing an instrument of this type is to enable the research fishing vessel to lower the midwater trawl to the exact depth zone where concentrations of fish occur, as determined by echo-sounding equipment. The work was done, under contract with the Fish and Wildlife Service, by the Marine Laboratory of the University of Miami, F. G. Walton Smith, Director. An existing and workable device, which was developed by the Woods Hole Oceanographic Institute and which was described in an unpublished manuscript by Willard Dow, was redesigned to meet specified requirements. The authors appreciate the cooperation of Reidar Sand, project leader, and the staff of the Fish and Wildlife Service station at Coral Gables, Florida.

UNDERWATER TELEMETER FOR DEPTH AND TEMPERATURE

A complete communication system consists of a transmitter, a transmission medium, and a receiver. In a telemetering system, the transmitter encodes or translates the desired information into a form which may be easily carried by the transmission medium and which may then be reclaimed at the receiving end. In many cases where high accuracy or high fidelity is required, serious design problems are encountered because each link of the telemetering "chain" has the ability, in one way or another, to scramble the information being transmitted and to destroy accuracy. Therefore, it becomes the duty of the design engineer to evaluate the variables and the sources of error and to use all the facilities at his command to maintain coherence of the information being transmitted.

Required performance

It was necessary to design an instrument to give continuous depth information over a range from 0 to 200 fathoms with a resolution accuracy having an error of not more than ± 1 percent. Reliable transmission was required over a distance of 5,000 feet.

The specified performance requirements determined the basic design of the instrument. In addition to accuracy, stability, operating distance, and operating time, there were numerous mechanical aspects to be considered, such as pressure seals and housings. The following sections present a detailed description of the completed instrument.

THE TELEMETERING SYSTEM

The telemetering system chosen for the instrument described in this report is a compromise. The problems of time, cost, and convenience weighed heavily in the electronic and mechanical design, and the finished unit is neither intended nor offered as the ultimate. However, the instrument seems to work exceptionally well and may prove to be a dependable and flexible device, which, through modifications or variation, could provide numerous services to studies of oceanography and marine biology.

In order to obtain high resolution, an FM system was chosen in which exceptionally large deviations are used to express the desired variable depth. This is the major difference between the present design and that developed by Willard Dow, which used straight primary

frequency regulation to express depth variations. By using FM, small variations in frequency due to circuit instabilities are minimized as sources of error. The frequency range chosen for the carrier is approximately 21 to 36 kilocycles (kc.), which allows an instability of ± 150 cycles per second (c.p.s.) as a ± 1 percent error. Temperature information is transmitted as amplitude modulation of the carrier with a sine wave tone whose frequency varies approximately as the temperature.

A Navy-type RBA-6 low-frequency radio receiver was available for use as a telemetering receiver. It was felt that a 1-percent system accuracy could be maintained if frequent calibration checks were made and if extremely high stability were achieved in the transmitter.

As first planned, the transmission mechanism was to be electrical; that is, the carrier signal was to be propagated electrically up the uninsulated trawl cable, using the water as a return path. However, a preliminary trial indicated that this system was impractical because of a high electrical noise level aboard the M/V GERDA and because a failure of electrical connections between the tele-meter transmitter and the trawl cable. Being pressed for time, this method was not pursued further and, after consultation with Dow, an acoustic link was employed. A choice of transducers allowed the incorporation of directional units with their attendant effective transmitting and receiving power gain. In addition, the directional receiving transducer was able to discriminate against undesirable sounds, such as screw noises. Dow outlined a system in which the receiving transducer was kept aimed in the general direction of the transmitter by sliding it a short distance down the trawl wire, using the wire angle for alignment. (See fig. 1.)

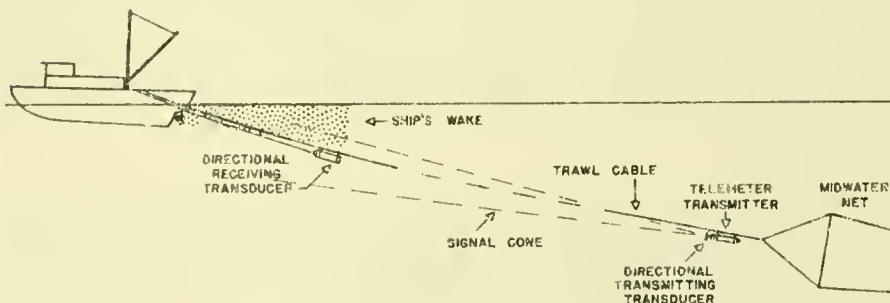

Fig. 1. Diagram of Telemeter System

DESIGN DETAILS

The Pressure Transducers

The heart of a system of this type is, of course, the transducers used to sense the unknown variable. Depth is measured by sensing pressure, and it was necessary to obtain a pressure transducer that could be used in the range of 0 to 1,200 feet, 0-537 pounds per square inch gage (p.s.i.g.), with less than 1-percent inherent error, including hysteresis. Inasmuch as the oscillator to be controlled was planned as a highly stable R-C type, it was desirable to have a pressure transducer that was a potentiometer suitable for use in the proposed circuitry. The pressure transducer chosen was a Model 304 miniature gauge pressure potentiometer, manufactured by Bourne Laboratories, Inc., of Riverside, Calif.

The R-C oscillator circuitry required two resistance arms, which necessitated the use of two units. The chosen pressure range was from 0 to 600 p.s.i.g., which would allow a maximum depth of 1,340 feet. The use of two pressure potentiometers resulted in less friction and hysteresis than would be possible to obtain in one unit with dual resistance elements.

In order to prevent exposure of the Bourdon elements of the pressure potentiometers to salt water, a hydraulic system employing an intermediate liquid (glycerine) and a rubber bulb was utilized. Because of the possibility of air entrapment, the Bourdons and the hydraulic tubing were filled under vacuum with glycerine. Annealed copper tubing was used, and all fixed joints were silver-soldered.

ELECTRONIC CIRCUITS

Transmitter

The transmitter contains 6 vacuum tubes, 2 germanium diodes, and 1 neon voltage regulator. It generates a frequency and amplitude modulated carrier between 21 and 36 Kc., at a power level of 1 to 2 watts. The unit is completely self-contained and will operate continuously for as long as 15 to 20 hours on one battery loading. (See fig. 2.)

Considerable time was spent investigating the relative merits of the many types of variable-frequency oscillators in order to choose a design for the depth oscillator that would provide accuracies within the prescribed limits. Finally, an R-C oscillator, whose tuned circuit has the configuration of a Wien bridge, was chosen. This type of oscillator permits the use of the above-mentioned pressure potentiometer as control elements, thereby simplifying the mechanical construction.

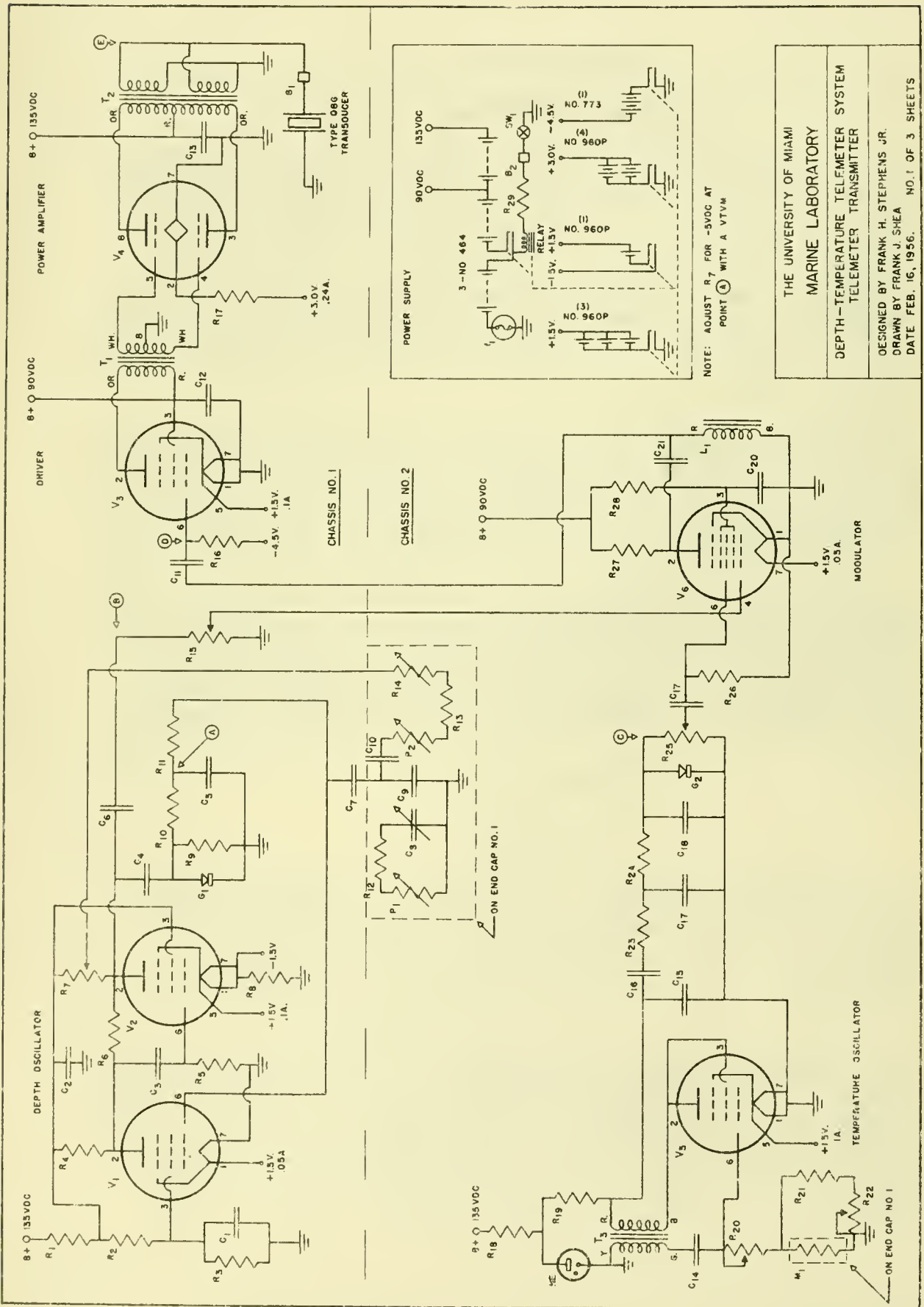

Fig. 2. Telemeter Transmitter Circuit Diagram.

Several breadboard models of Wien-bridge oscillators were constructed; however, all of them were found to be very sensitive to power-supply fluctuations. Batteries used in this instrument should have an end-point voltage about 20-percent down, therefore, such a degree of sensitivity on the part of the oscillator would make the circuits unusable during a power fluctuation. Frequency instabilities of several kilocycles were noted where both plate and heater supplies were varied, and the errors compounded themselves.

A new oscillator design, extremely stable with regard to power-supply fluctuations, was finally evolved. In this design, the proper use of negative feedback and the use of a variable- μ pentode for amplitude control practically eliminated frequency shift resulting from supply-voltage changes. By using heater-type tubes (6SK7-6V6), it was possible to maintain frequency (within 20 c.p.s.) even though plate-supply voltage was more than doubled. In addition, amplitude and frequency were constant for more than 10 seconds after the heater current was interrupted; after 10 seconds, the oscillations ceased abruptly.

Although it was necessary to redesign this oscillator for operation with miniature battery-type tubes, stability was sacrificed to only a very slight degree. It was necessary to provide a self-biased resistive cathode for the second amplifier tube, which, when using battery tubes, required an isolated and separate battery. Because of current drawn by the rectifier in the automatic-gain-control (a.g.c.) circuit, the output waveform for this particular oscillator is not so good as that obtainable with a conventional Wien-bridge oscillator. However, a few-percent distortion in this service is entirely negligible.

The depth-frequency characteristics of the completed circuit will be a function of the degree of linearity of the pressure potentiometers. The Wien-bridge oscillator has an operating frequency that is about equal to $1/2\pi RC$, when R and C are the resistance and capacitance of the component parts of the reactive arms of the bridge. Variation of frequency is linear with respect to changes in R or C. Rough measurements of linearity of the oscillator indicate a value of more than 3 percent over the entire range.

The operation of the telemeter may be described as follows:

In referring to the schematic diagram (fig. 2), tubes V_1 and V_2 (type 1T4 and 3V4, respectively) are used as the depth oscillator, described above. They are located on the same chassis as V_3 and V_4 and comprise a necessary two-stage amplifier of the R-C oscillator.⁴ The phase-shifting network is mounted on one end-cap of the instrument and consists of the two pressure potentiometers, three resistors, and three capacitors. One of these resistors, R_{14} , and one capacitor, C_8 , are adjustable and function as high-frequency and low-frequency

calibration adjustments, respectively. G_1 (type 1N54-A germanium diode) functions as the a.g.c. rectifier and supplies the control bias for the variable mu amplifier, V_1 . Positive feedback is adjustable by means of R_7 , which, of course, sets the level of oscillation. This is adjusted so as to provide -5 volts, d.c. at point A, as measured with a vacuum-tube voltmeter. This adjustment is made at the lowest operating frequency.

V_6 (1R5) follows V_1 and V_2 and serves two purposes: it acts as a buffer amplifier between the oscillator and driver, V_3 , and it is used as a modulator that mixes the depth and temperature signals so they may be transmitted together. The plate circuit of V_6 contains a single section--constant k, T high-pass filter--which has a low-frequency cutoff of about 10 kc. It prevents the modulating signal (about 200 to 800 c.p.s.) from appearing at the grid of the class-A driver, V_3 . The carrier level is adjusted independently of modulation level by R_{15} and is set while observing the output waveform at the secondary of T_2 when it is properly loaded.

V_3 (3V4) operates as a class-A amplifier and supplies the energy necessary to properly drive the grid of V_4 , the 1J6GT class-B power amplifier.

The class-A driver and class-B output transformers, T_1 and T_2 , and the filter reactor, L_1 , were designed and wound at the Marine Laboratory. The modulating signal is supplied by the temperature oscillator, V_5 , a 3V4 blocking oscillator. The temperature-sensing element is a type 51R2 thermistor made by Victory Engineering Co. It is encased in a special oil-filled brass housing, which is screwed into the end cap of the instrument. High-temperature and low-temperature limit calibration adjustments are provided by R_{20} and R_{22} , respectively. The "sawtooth" output from V_5 is shaped by an R-6 network, described above. In reality, this is not an undesirable effect. Modulation would be increased in colder water, which, in general, would be deepest. A slight saving in battery power may result at shallow depths, where the water is warmest.

Of course, other information could be impressed on the carrier by means of the modulator, which, when tested in the laboratory, was fairly linear. Adjustment of modulation percentage, independently of carrier level, may be made by R_{25} . This adjustment should be made at the low-temperature limit, while observing output waveform at the secondary of T_2 in order to avoid overload, which would cause a multiplicity of sidebands and make it difficult to identify the carrier on the telemeter receiver.

The transducer is affixed to the telemeter housing with a clamp that allows positioning at various angles in order to pre-set its

transmitting direction. The transducer is a Navy-type QBG crystal unit, which, because of its size, shows directional characteristics and power gain. It was chosen because of these characteristics, and, although its resonant point lies at about 26 kc., it was thought that sufficient energy would be radiated over the desired range (21 to 36 kc.) if it were fed at 150 ohms impedance. The 26 kc. high-efficiency point would be near the proposed optimum operating depth (100 fathoms).

Waveforms

A reproduction of two polaroid oscilloscope photographs are shown in figures 3 and 4. The first photograph (fig. 3) shows modulated waveforms; the second photograph (fig. 4) shows carrier and modulating waveforms.

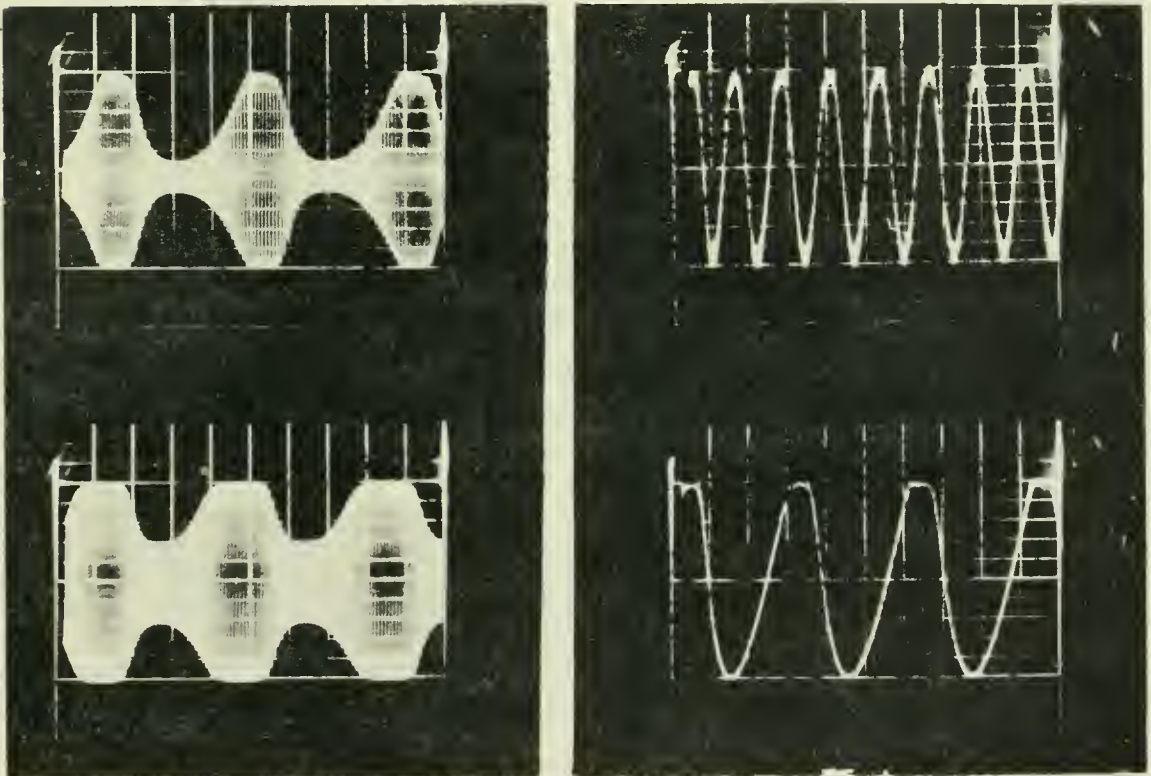

Fig. 3. Sample modulated wave-
form signals.

Fig. 4. Carrier waveform signal
(above) modulating wave
form signal below.

The top modulated waveform (fig. 3) was taken at point D, the driver grid, and measured 9.5 volts peak-to-peak. The second modulated waveform (fig. 3) was taken at point E, across the secondary

of T_2 when loaded by 150 ohms. It shows a compression of modulation due to non-linearity in the class-B amplifier, V_4 , at the 2-watt level. Voltage at this point is about 50 volts peak-to-peak.

The 21-kc. carrier is shown at the top of figure 4 as it appears at the mixer grid, point B. The voltage at this point is 10 volts peak-to-peak at 21 kc. The slight distortion caused by the a.g.c. diode can be seen on positive waveform peaks. The fuzzy waveform peaks are due to coupling of a small amount of modulating voltage through the B+ line. Increasing the size of C_2 , and substituting a choke for R_1 , would eliminate this problem; however, no deleterious effects upon the operation were noted, and the necessary extra space was not available. The depth oscillator showed a very slight tendency to lock to harmonics of the temperature or modulating waveform and when waveform peaks coincided; however, pulling was very slight.

The modulating waveform shown at the bottom of the second polaroid photograph (fig. 4) was taken at point C, and it measured 3.2 volts peak-to-peak at 520 c.p.s. It is a modified sawtooth, which is altered by the network containing R_{23} , R_{24} , R_{25} , C_{17} , C_{18} , and G_2 .

Receiver

The telemetering receiver used in this system is a Navy-model RBA-6, low-frequency, radio receiver type CJT 46300. It is used in an unaltered condition; however, the system required auxiliary receiving equipment. This auxiliary equipment consists of a cathode-follower transducer isolation amplifier and a low-noise, high-gain preamplifier. These units are described below.

A cathode-follower amplifier, V_7 (6AH6), is contained in the receiving transducer housing and is powered through the multi-conductor cable connecting it to the preamplifier at the receiver. V_7 is used to isolate the crystal receiving transducer from the low-impedance cable connecting it to the preamplifier, and thus it prevents loading. This tube also provides a low-impedance source to drive the bandpass filter located in the preamplifier. An electrical schematic drawing of these units is shown in figure 5.

A preamplifier consists of two tubes, V_8 and V_9 . V_8 is a 6BK7A, which is used as a high-gain, low-noise, cascade amplifier, and V_9 is a 12AU7, which is used as a triode amplifier and cathode-follower output. A bandpass filter is used at the input of the unit to exclude undesirable electrical voltages outside the frequency range used for telemetry and to prevent cross-modulation and generation of unnecessary interference. The bandpass of this filter is 1.5 to 100 kc.,

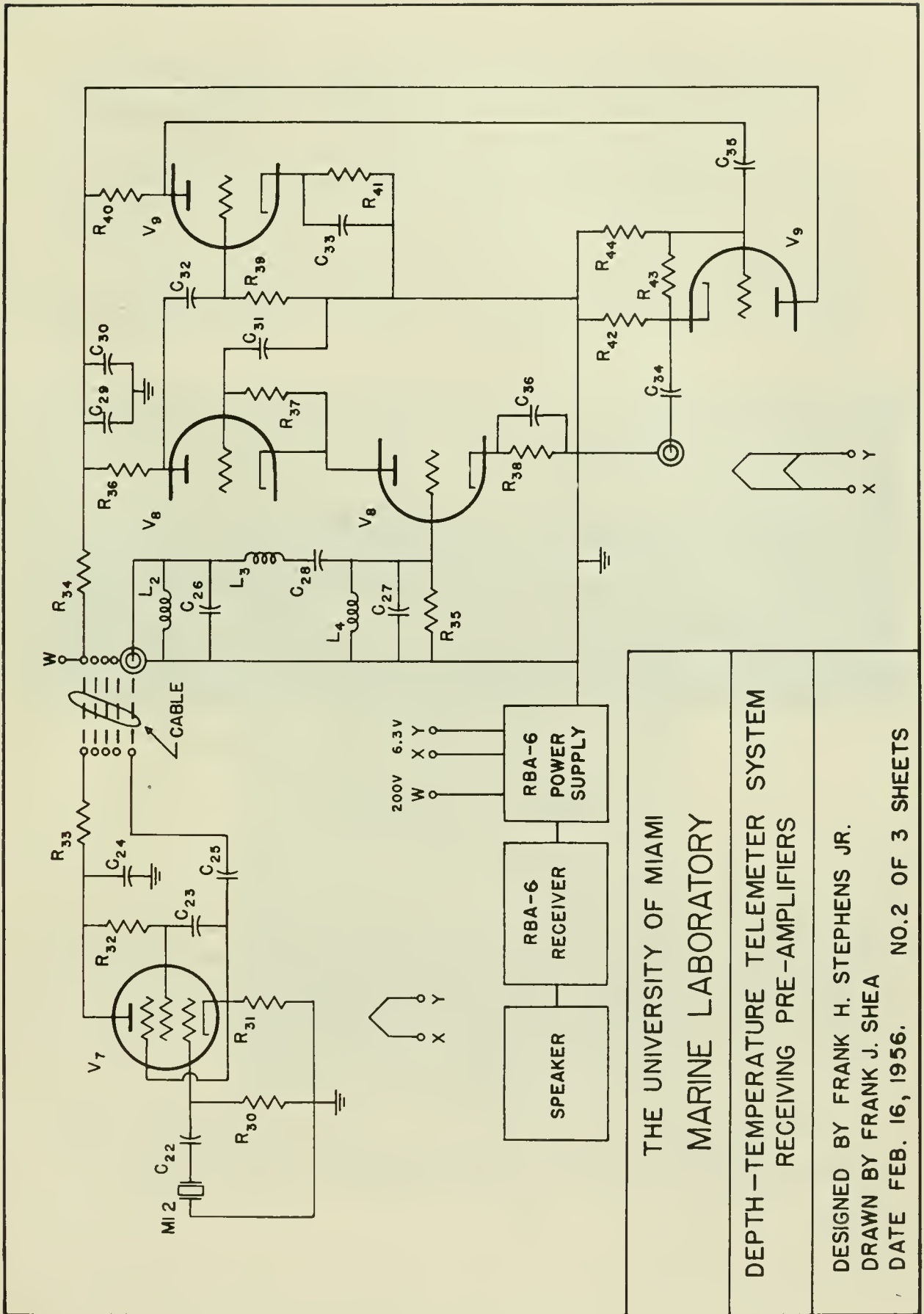

Fig. 5. Telemeter receiving pre-amplifier circuit diagram.

which will exclude power and low-frequency radio signals. The use of the preamplifier was to increase the signal-to-noise ratio of the receiving system and to provide the utmost sensitivity possible.

The receiving transducer is a type MI-2 mine hydrophone and, although no information was available concerning its use of frequency response, it appears to be suitable over the 20- to 40-kc. range. It consists of a Rochelle-salt array, about 3-1/2 inches in diameter, which, when considered as a piston, would have a useful directivity pattern at these frequencies. It is fitted with a large flanged pipe, capped at one end, which contains the 6AH6 cathode-follower amplifier. In use, this assembly is suspended over the stern to a point just below the ship's wake.

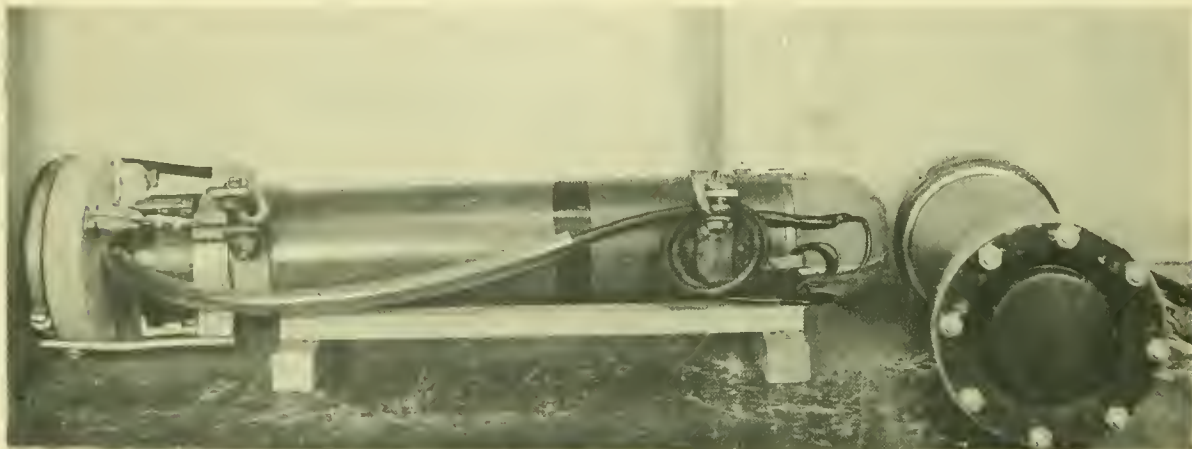

Fig. 6. Telemeter transmitter and receiving hydrophone

MECHANICAL DESIGN

Telemeter Case

This consists of a 5-1/4-inch-inside-diameter (I.D.) steel cylinder, 27-1/4 inches long with a 1/4-inch-thick wall. The inside surfaces of the ends are machined and ground. A 1/4-inch relieved lip on each end has been machined to prevent damage to the O-rings during assembly of the instrument. There are also three anchor points on each end of the case for attachment of L-shaped clamps to retain the end caps.

End Caps

(a) The end caps are machined from cast brass blanks. The caps are 5-3/4 inches wide on the 3/8-inch-thick flange and are

5-1/4 inches wide on the 1-1/8-inch barrel. Each cap is machined for two O-rings, type PRP-902-54 or National 622754. The O-ring seal was designed for a 1,500 p.s.i.g. non-moving seal. Because the inside diameter of the telemeter case did not conform to the standard O-ring size, it was necessary to recompute the groove, ring clearance, ring cross section, and similar information. This is for only one ring per end-cap; the second ring was added for safety.

(b) One end-cap top is blank to allow for the transducer pivot clearance. The other end-cap top contains the depth and temperature-sensing elements and the two feed-throughs.

The Depth-Sensing Assembly

The depth -sensing assembly consists of a sealed passage connecting the two pressure potentiometers to the external water pressure. The external exposed section is a rubber bulb served on a machined nipple that is threaded and sealed in the end-cap. On the inside of the telemeter case there is another threaded nipple in the end-cap with a drilled head to take two pieces of 3/16-inch-outside-diameter (O.D.) annealed copper tubing. This tubing is silver-soldered to the nipple, and the other ends have flare fittings that connect to the pressure potentiometers. This system is filled with glycerine under vacuum, and is, therefore, free of air bubbles.

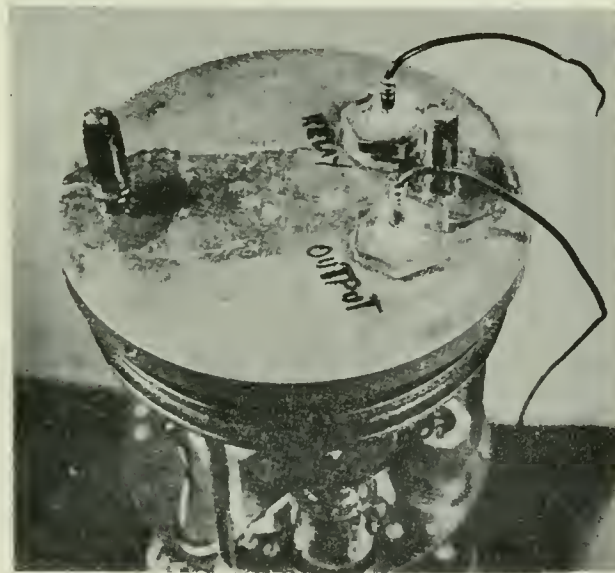

Fig. 7. Transmitter end bell showing rubber pump, metal thermistor housing and terminal seals.

The Temperature-Sensing Element

This sensing element is a 51R2 thermistor contained in a brass-walled cylinder that is threaded into the end-cap. This brass cylinder has a 13/32-inch O.D., and is 1-1/2 inches long. It is bored in two stages, one to take the insulated thermistor and the other to take the threaded bakelite plug. The bakelite feed-through plug is drilled to take the two thermistor wires. The cavity containing the thermistor is filled with mineral oil, the bakelite plug is run in, then the feed-throughs are sealed off.

The Feed-Throughs

These are for the signal switch and the water switch, and are located on the above-mentioned end-cap. Both feed-throughs are identical in construction; therefore, only one will be described here. A 3/4-inch-diameter hole, 1-1/8 inches deep, is bored into the end-cap, which houses all of the parts in the feed-through assembly. Starting at the bottom of the hole, a lucite disk (0.740-inch diameter, 3/8-inch thick) containing a clearance hole through the center for a 1/8-inch-diameter brass rod 1-1/2 inches long, and a groove mid-way up the side of the perimeter for a PRP-902-11 O-ring, is placed in the position first. This forms a seal between the assembly and the wall of the hole in the end-cap. After this seal, a brass disk (0.625-inch diameter, 1/4-inch thick) with a 1/8-inch shaft anchored to the center of the bottom, and a PRP-902-7 O-ring in the peripheral area of the bottom side of the disk, is placed on the lucite disk. The 1/8-inch brass rod is insulated, where it passes through the body of the end-cap, with a length of insulating sleeve. The insulated lead is connected to the top of this disk. The lucite disk and the brass disk, with their associated O-rings, form the water-tight seal for the electrical feed-through. Above the brass disk is another lucite disk (0.725-inch diameter, 1/4-inch thick) with a 1/16-inch hole through it for the insulated lead and attaching plate. This disk serves as an insulator between the brass disk and the threaded hex-head plug (3/4 inch, 14 thread, by 3/8 inch) that completes the assembly. This plug has a 0.102-inch-diameter hole through it for the insulated lead, and a bored brass sleeve (3/16-inch O.D., 3/4 inch long) silver-soldered on top, concentric with the hole, to serve as a mounting post for a piece of surgical rubber tubing (1/4-inch O.D., 3 inches long). The rubber tubing, or boot, serves as a reservoir for the silicone high-vacuum grease and as a stiffener for the wire to distribute flexing. The feed-throughs and rubber tubing are packed with vacuum grease, carefully excluding all air bubbles, then the tubing is served off tightly at both ends. These feed-throughs are designed to withstand a pressure of 1,500 p.s.i.; however, to increase the safety factor would require enlarging the feed-through assemblies to accommodate the additional O-rings, which would then cause numerous design complications.

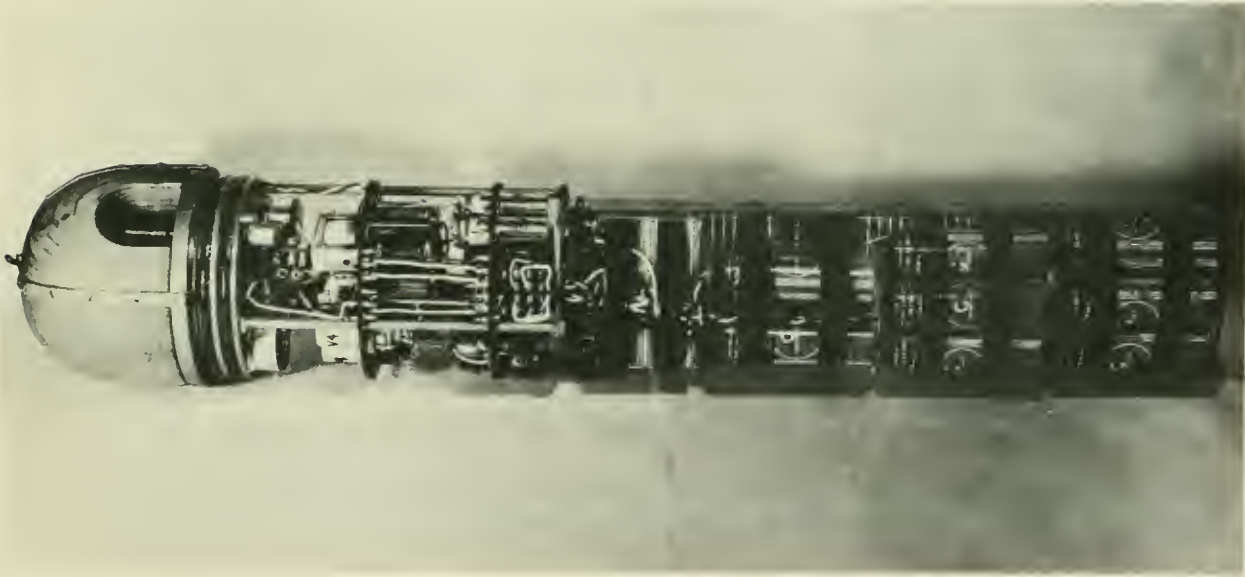

Fig. 8. Transmitter assembly showing fairing block, electronics stack, and battery load.

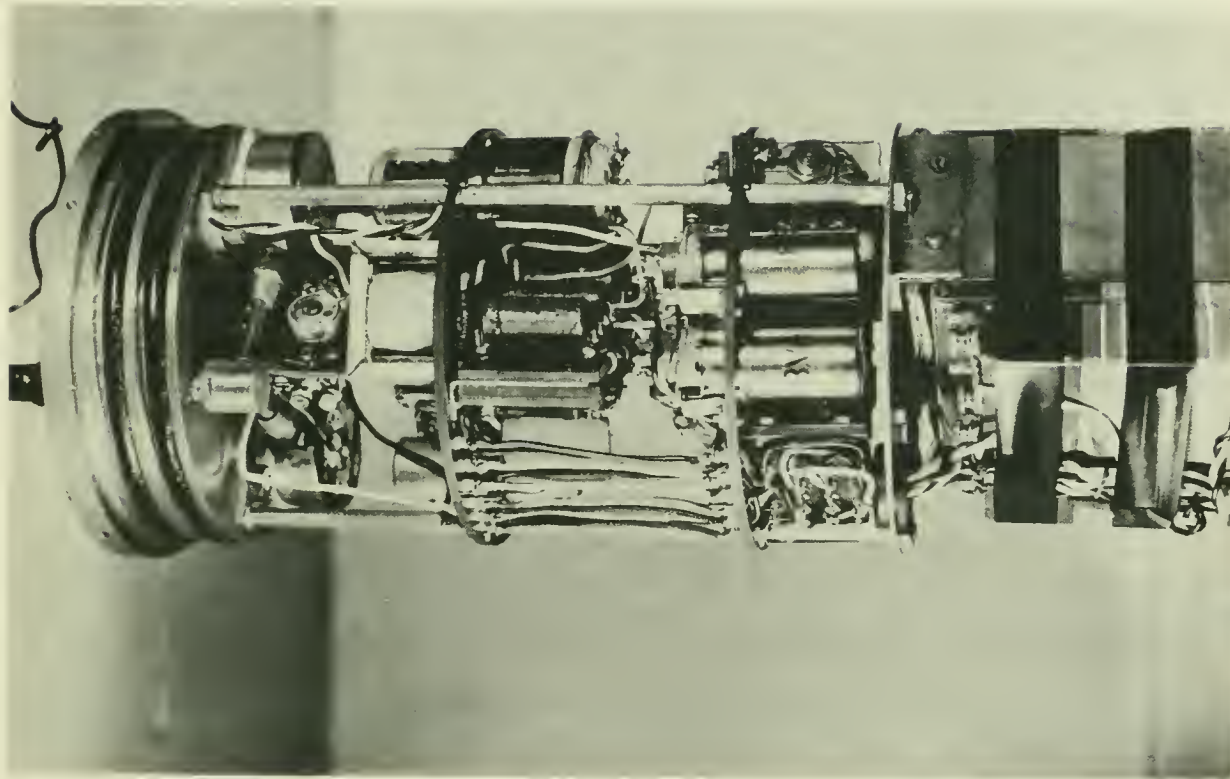

Fig. 9. View of electronics stack showing Bourdon elements and circuitry.

The Streamlined Nose-Piece

The wooden nose-piece was designed to protect and direct a balanced flow of seawater on the end cap, which houses the sensing elements when the telemeter was being towed through the water with the sensing elements facing forward. This nose-piece houses the seawater switch, which is a 1/4-inch O.D. lucite rod with a heavy brass slug where the insulated wire from the battery relay is attached. The electrical circuit is completed whenever water completes the circuit between the brass slug and the metal telemeter housing. The exposed end of the relay wire is coated with either rubber cement or 3M Scotch Fill.

Fittings

(a) The transducer mount is constructed of 1/4- by 1-1/2-inch brass rectangular stock. It is a two-piece band with brass spacer blocks to carry the supporting arms, which hold the type QBG transducer. The directional adjustment is approximately -15° to $+45^{\circ}$ for the axis of the transducer.

(b) The hangers are also constructed of 1/4- by 1-1/2-inch brass rectangular stock, and both are one-piece-type clamp bands. One hanger has a single mounting arm and shackle, and the other hanger has two mounting arms and shackles placed diametrically opposite each other.

(c) The three-fin tail assembly is constructed of 1/4- by 1/4-inch brass rectangular stock framework with 0.017-inch sheet brass. These three fins are mounted on a two-piece band (1/8- by 1-inch brass rectangular stock) forward, and are held firmly aft to the telemeter case with a band (1/16- by 1-inch brass rectangular stock) encircling the circumference of the fins and anchored at the three points on the telemeter case.

This arrangement will allow a number of mounting possibilities:

- (1) Towing with fins and a bridle.
- (2) Towing with fins, bridle, floatation equipment, and ballast on other hanger.
- (3) Attached to trawl cable with both hangers.
- (4) Mounted on trawl wings with both hangers.
- (5) Mounted in the mouth of trawl net with both hangers.

Hydrophone Case

This is a 6-inch I.D. steel-wall pipe, 18 inches long with a 1/4-inch-thick wall. One end of this pipe is threaded, and an end-cap is firmly screwed on; then a complete brazed joint is made around the threaded joint. On the other end, a 8-3/16- by 1-inch brass flange is brazed onto the pipe. This flange is machined for a PRP-902-64 O-ring, eight 7/16-inch stud holes, and a standard 5-inch non-tapered pipe thread on the inside diameter. It will accommodate an MI-2 mine hydrophone at present, but other hydrophones may be used by attaching custom-made adapters on the 5-inch non-tapered pipe thread.

A No. CC1045 H.H. Buggie-cable feed-through gland is mounted on the end-cap for the power and signal cable.

A treated wooden nose piece fits on the pipe end-cap for streamlining purposes, and is banded with 3/8-inch oval brass.

The matching amplifier is shock mounted to the back cover of the MI-2 mine hydrophone.

The hangers (1/4- by 1-inch brass rectangular stock) are clamp-type bands which attach the hydrophone assembly to the trawl cable. The hangers can mount marlin-served shackles, or guarded sheaves can be fabricated if the cable-shackle noise level should be annoying.

Batteries

The battery section of the telemeter contains Eveready batteries No. 484, No. 960P, and No. 773. It is necessary to keep cardboard spacers between (1) the No. 484 batteries to allow wire and plug clearance and (2) the No. 960P to provide insulation between bottom of cells and chassis ground, wires, and plugs. Placing insulating tape on the bottom of the cells provide an additional safety factor against shorts.

Maintenance

It must be emphasized that for the proper performance of this equipment, as far as water leaks are concerned, the O-ring seals, feed-throughs, and rubber tubing must be properly inspected, cleaned, and coated or packed with silicone high-vacuum grease before the instrument is put into operation.

After each use of the instrument, the O-rings that seal the end caps into the telemeter case and the O-ring that seals the MI-2 mine hydrophone must be inspected, cleaned, and re-coated before re-use or

storage. Periodic inspections of the feed-through assemblies will be necessary. Re-packing should be determined by condition of assemblies.

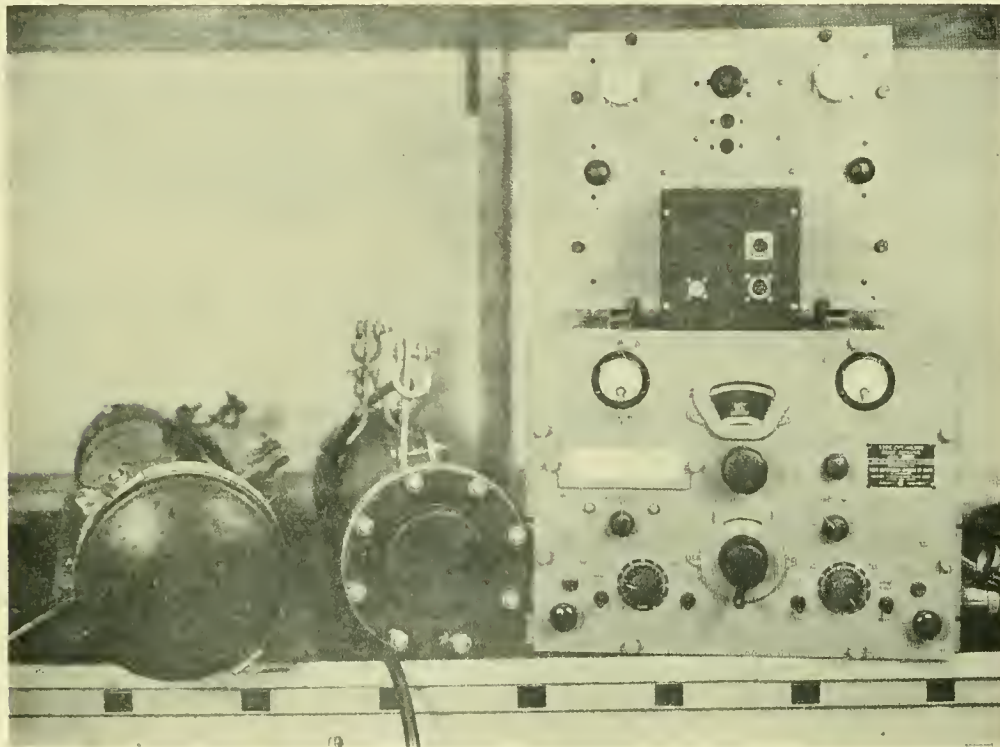

Fig. 10. Telemeter assembly showing transmitter, receiving hydrophone, power supply, pre-amplifier, and RBA-6 receiver.

TRIALS AND TESTS

Two tests of the completed instrument were run: a test for distance, and a test for depth.

Distance and Directivity

A shallow-water distance test was run in Government Cut at Miami Beach, Fla. The receiver and receiving transducer were on shore at a vantage point enabling a clear shot across the channel for approximately 1.2 miles. During the test, there was considerable noise from the various power boats in the immediate vicinity, and conditions were by no means ideal. The telemeter transmitter was suspended from a small motor launch to a depth of approximately 7 feet. Excellent signals were received as far as 1 mile, and extremely strong signals were received at 3,000 feet. Tone modulation was readable at all times.

Received signal voltages at the preamplifier input measured about 100 and 500 microvolts ($\mu.v.$) at 1 mile. These levels were at least 20 decibels (db) above the ambient noise levels at the receiver output. A measurement of receiver-system noise showed that the self-noise of the receiver-preamplifier combination is 6 db below 0.09 $\mu.v.$ at 21 kc., which shows a tremendous margin of sensitivity for use in quiet waters. Of course, use in oceanic water will afford much better ambient noise conditions than Biscayne Bay, which was full of motor vessels and biological noisemakers.

As expected, multiple-path transmission caused extreme variation in signal strengths during this test, and it was difficult to establish exact figures for directivity. The fading was strikingly similar in amplitude and period to that experienced in low- or medium-frequency radio transmissions at or near ground-wave limits. Amplitude excursions of 20 db were noticed under certain conditions.

At distances of approximately 1 mile, variations in the position of the transmitting transducer within a 40° horizontal angle did not seriously affect the received signal. Transmission, at times, was obtainable with reflected energy from the large stone breakwaters 100 feet behind the transmitter. At 1,500-foot range, overload of the receiver was experienced and extremely strong signals were received regardless of the transmitter's direction. Test personnel aboard the motor launch were able to hear the received tone from the receiver loudspeaker on shore, a distance of 2,000 feet.

The MI-2 hydrophone assembly was suspended by rope from a pole at the seawall at the southeast corner of the Coast Guard base. Movement of this unit to determine directivity characteristics indicated, as would be expected, a much broader pattern. The receiving pattern seemed to be about 20° or 30° wider than that of the QBG transducer transmitter.

The above observations were made at 21 kc. (the surface frequency). Transducer gain will be greater at the higher frequencies, due to the sharper directivity patterns expected, and the figures given here may vary widely.

Depth

A trip to sea aboard the M/V GERDA was made for depth tests in order to check pressure housing and seals of the telemeter transmitter. Inasmuch as seas were moderate and there was a wind of about 10 knots, it was impossible to lower the telemeter without a considerable cable angle. This angle increased with depth and made it impossible to ascertain the exact depth of the telemeter transmitter. Therefore,

accurate calibration of the system for depth was impossible. Rough computations made by considering apparent wire angle at the surface indicated a depth of 366 meters; however, frequency indications on the receiver showed an approximate depth of 212 meters.

It appears that conditions during this test were rather extreme as far as currents were concerned, and the results show the necessity for laboratory-controlled pressure tests.

Calibration procedures were extremely simple and only required the connection of a hydraulic pressure line to the pressure potentiometers in order to apply a known pressure accurately simulating the desired depth. This hydraulic test was subsequently run on a calibrated hydraulic dead-weight tester. The calibration was run from atmospheric pressure to 575 p.s.i.g. in increments of 25 p.s.i.g., and then back down to atmospheric pressure in the same 25 p.s.i.g. steps. In calibration tests, as in field operation, the RBA-6 receiver is tuned to the transmitted signal. The frequency indicated on the dial is then interpreted in feet or fathoms from the plotted curve. A descriptive plotting chart has been prepared, which allows easy and quick reference.

With this information, it was then possible to compute the actual maximum depth that was obtained during the depth tests aboard the M/V GERDA. This calculation shows the maximum depth to be approximately 263 meters (+1 percent).

The testing of pressure seals would require a test chamber. However, well-designed pressure seals generally perform in the expected manner and, if properly handled, very seldom fail.

The telemeter functioned properly during the depth test, and inspection of the O-ring seals showed no leakage. The junction box on the rear of the QBG transducer leaked, and sufficient water entered to cause a partial short of exposed terminals. During preparation for this test, precautions were taken concerning this particular weak point by filling the cavity in the box with glycerine. However, the cable leading through the gland nut contained a hemp filler that absorbed the glycerine and left an air space. The extreme hydrostatic pressure to which this fitting was exposed during the test forced the rubber gland into the empty chamber and allowed water to enter. This condition has been eliminated by use of a different type of cable, containing no filler or air space.

Temperature

No calibration curve has been run on the temperature system; however, it is a simple procedure to perform in the laboratory. The

telemeter can be suspended upside down with the sensing element immersed in a controllable temperature bath; then, as the bath is altered, an audio oscillator is adjusted for zero beat against the modulated tone of the RBA-6 receiver. After a number of points have been recorded, a curve can be plotted to serve as the temperature-modulated tone-conversion table.

REFERENCES

1. DOW, Willard. Underwater Telemetry: A Telemetering Depth Meter, Woods Hole Oceanographic Institution Ref. 54-39, (Unpublished Manuscript.)
2. TERMAN, F. E., and J. M. Pettit. Electronic Measurements, McGraw-Hill Book Co., Inc. 1952, New York, N. Y.

APPENDIX A.

Depth Calibration Results

HYDRAULIC TEST OF SENSING ELEMENTS FOR DEPTH CALIBRATION

PRESSURE	LOG SCALE DIAL READINGS	
	Set. I*	Set II*
<u>p.s.i.g.</u>		
0.....	262.3	268.8
25.....	286.8	285.8
50.....	301.0	301.3
75.....	320.1	320.1
100.....	337.4	338.1
125.....	357.7	355.9
150.....	375.5	374.3
175.....	395.0	391.8
200.....	416.6	414.2
225.....	433.0	433.0
250.....	456.8	455.1
275.....	474.7	475.1
300.....	498.8	500.0
325.....	523.1	521.4
350.....	550.7	550.5
375.....	576.1	577.2
400.....	506.7	604.8
425.....	638.2	636.2
450.....	670.0	668.3
475.....	707.9	704.8
500.....	742.5	743.2
525.....	778.8	777.0
550.....	820.6	818.0
575.....	860.2	858.2

* The 268.8 figure of Set II was rechecked at end of run; therefore, the 262.3 figure of Set I is believed to be caused by insufficient warmup of the equipment.

R ₁	1000 Ohms	1/2W	Deposited Carbon	(IRC) 1% Resistor
R ₂	25K "	1/2W	" "	" " "
R ₃	50K "	1W	" "	" " "
R ₄	50K "	1W	" "	" " "
R ₅	1 Megohm	1/2W	" "	" " "
R ₆	150K Ohms	1/2W	" "	" " "
R ₇	7.5K "	2W	(WW)	Potentiometer
R ₈	1.5K "	1/2W	Deposited Carbon	(IRC) 1% Resistor
R ₉	150K "	1/2W	" "	" " "
R ₁₀	100K "	1/2W	" "	" " "
R ₁₁	2 Megohms	1/2W	" "	" " "
R ₁₂	10 K Ohms	1/2W	" "	" " "
R ₁₃	10 K "	1/2W	" "	" " "
R ₁₄	1000 "	2W	(WW) Type AB	Potentiometer
R ₁₅	250K "	2W	Type AB	"
R ₁₆	100K "	1/2W	Deposited Carbon	(IRC) 1% Resistor
R ₁₇	3.9K "	1W	Carbon	Resistor
R ₁₈	100K "	1/2W	Deposited Carbon	(IRC) 1% Resistor
R ₁₉	200K "	1/2W	" "	" " "
R ₂₀	5K "	2W	Type AB	Potentiometer
R ₂₁	2 Megohms	1/2W	Deposited Carbon	(IRC) 1% Resistor
R ₂₂	1 "	2W	Type AB	Potentiometer
R ₂₃	100K Ohms	1/2W	Deposited Carbon	(IRC) 1% Resistor
R ₂₄	100K "	1/2W	" "	" " "
R ₂₅	1 Megohm	2W	Type AB	Potentiometer
R ₂₆	2 "	1/2W	Deposited Carbon	(IRC) 1% Resistor
R ₂₇	100K Ohms	1/2W	" "	" " "
R ₂₈	85K "	1/2W	" "	" " "
R ₂₉	4.7K "	1W	Carbon	Resistor
R ₃₀	470K "	1W	Deposited Carbon	(IRC) 1% Resistor
R ₃₁	150K "	1W	" "	" " "
R ₃₂	47K "	1W	" "	" " "
R ₃₃	1000 "	1W	" "	" " "
R ₃₄	1000 "	2W	" "	" " "
R ₃₅	75 "	1/2W	" "	" " "
R ₃₆	15K "	2W	" "	" " "
R ₃₇	470K "	1/2W	" "	" " "
R ₃₈	100 "	1/2W	" "	" " "
R ₃₉	1 Megohm	1/2W	" "	" " "
R ₄₀	15K Ohms	2W	" "	" " "
R ₄₁	1500 "	1/2W	" "	" " "
R ₄₂	15K "	1/2W	" "	" " "
R ₄₃	150K "	1/2W	" "	" " "
R ₄₄	1 Megohm	1/2W	" "	" " "
P ₁	10 K Ohms	-	Pressure	Potentiometer
P ₂	10 K "	-	"	"
(P ₁ and P ₂ manufactured by Bourmes Laboratories, Inc.)				
M ₁	Thermistor	Type 51R2		Resistor
(M ₁ manufactured by Victory Engineering Co.)				
C ₁	.25 Mfd	200 Volts	Paper	Condenser
C ₂	.25 "	200 "	"	"

PARTS LIST -- Cont'd

C3	.1	mfd	200Volts	Ceramic	Condenser
C4	.001	"	200 "	Paper	"
C5	1.0	"	100 "	"	"
C6	200	mmfd	200 "	"	"
C7	.01	mfd	200 "	"	"
C8	4-30	mmfd	-	Trimmer	"
C9	260	"	600 "	Zero Drift TCZ260	"
C10	260	"	600 "	" " "	"
C11	160	"	600 "	Mica	"
C12	.25	mfd	200 "	Paper	"
C13	.25	"	200 "	"	"
C14	.06	"	200 "	"	"
C15	.02	"	200 "	"	"
C16	.02	"	200 "	"	"
C17	.002	"	100 "	"	"
C18	.003	"	100 "	"	"
C19	.01	"	100 "	"	"
C20	.1	"	200 "	"	"
C21	160	mmfd	600 "	Mica	"
C22	.05	mfd	600 "	Paper	"
C23	2.0	"	450 "	Electrolytic	"
C24	12	"	450 "	"	"
C25	20	"	25 "	"	"
C26	.026	"	400 "	Paper	"
C27	.026	"	400 "	"	"
C28	.623	"	400 "	"	"
C29	40	"	450 "	Electrolytic	"
C30	.1	"	600 "	Ceramic	"
C31	.1	"	600 "	"	"
C32	.01	"	600 "	"	"
C33	.1	"	600 "	"	"
C34	.05	"	600 "	"	"
C35	.01	"	600 "	"	"
C36	.1	"	600 "	"	"
L1	0.8	hy			Choke
L2	6.494	mh	Miller No. 6322		"
L3	.2696	mh	" "	6198	"
L4	6.494	"	" "	6322	"
V1	1T4		Tube		
V2	3V4		"		
V3	3V4		"		
V4	1J6GT		"		
V5	3V4		"		
V6	1R5		"		
V7	6AH6		"		
V8	6BK7A		"		
V9	12AU7		"		
T1	1.12	hy/1 volt/1000 cps, Primary			Driver Transformer
		(turn ratio--pri. to 1/2 sec. 2:1)			
T2	.49	hy/pri, .064 hy/sec.,			Output Transformer
		(10K ohms Class "B" to 150 ohms load output)			
T3	A-3000	Merit			Transformer
SW1					Water switch
B1	Water tight				Feed-thru
B2	" "				" "

MBL WHOI Library - Serials



5 WHSE 01712

